

Pronto, montagem concluída!

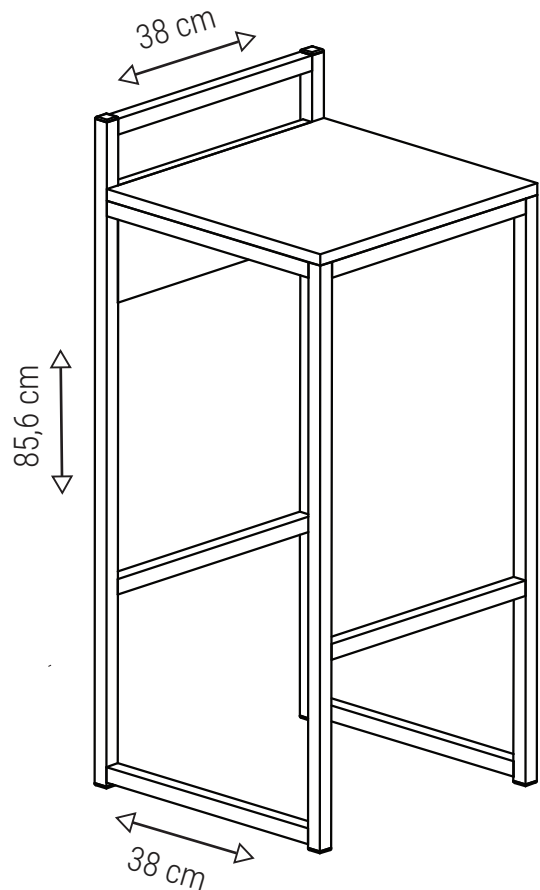

REV00\_SET2023

Para limpeza utilize pano limpo e seco. Nunca use produtos abrasivos.

Acesse o termo de garantia em:  
[multivisao.com.br/termos/termodecore.pdf](http://multivisao.com.br/termos/termodecore.pdf)

SAC  
[sac@multivisao.com.br](mailto:sac@multivisao.com.br)  
[multivisao.com.br](http://multivisao.com.br)  
☎ 11 4158-8700 📞 11 97338-5258

GRUPO  
**MULTIVISÃO**<sup>®</sup>  
Desde 1985

# BANQUETA

Taburete alto

LINHA  
**URBANA**

## INSTRUÇÕES DE MONTAGEM

### Componentes

- 1 Assento ①
- 1 Reforço ②
- 2 Traves laterais ③
- 4 Travessas ④

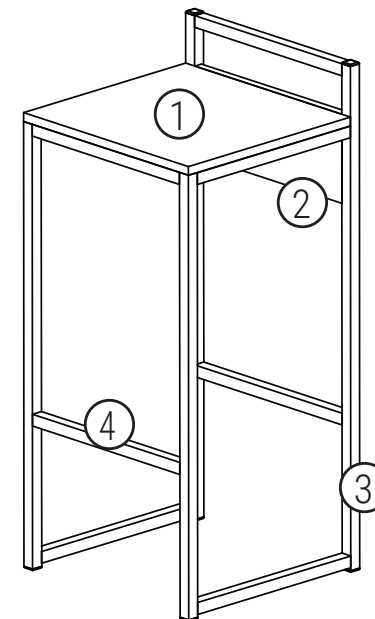

A 2 Parafusos  
4,5 x 50 mm

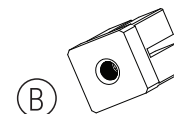

B 8 Buchas  
Expansivas



C 8 Parafusos  
1/4 x 1 1/2

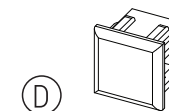

D 6 Ponteiros  
20 x 20



E 4 Parafusos  
5 x 30 mm

### Ferramentas necessárias



Chave Phillips



Martelo

GRUPO  
**MULTIVISÃO**<sup>®</sup>  
Desde 1985

1°. Fixe o reforço (2) no assento (1), utilizando os parafusos (A).

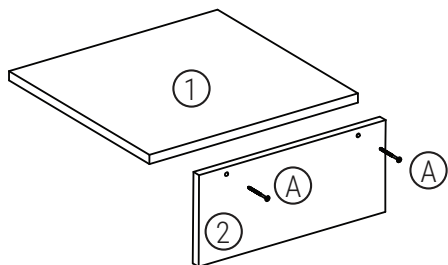

 1°. Fijar el refuerzo (2) sobre el asiento (1), mediante los tornillos (A).

2°. Encaixe as buchas expansivas (B) nas travessas (4) e as ponteiros (D) nas travessas laterais (3).

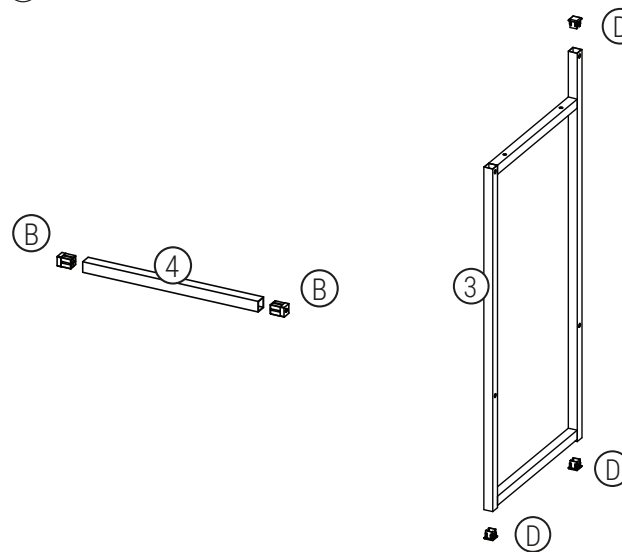

 2°. Montar los casquillos expansivos (B) en las vigas (4) y las puntas (D) en las vigas laterales (3).

3°. Fixe as travessas (4) nas laterais (3) utilizando os parafusos (C).

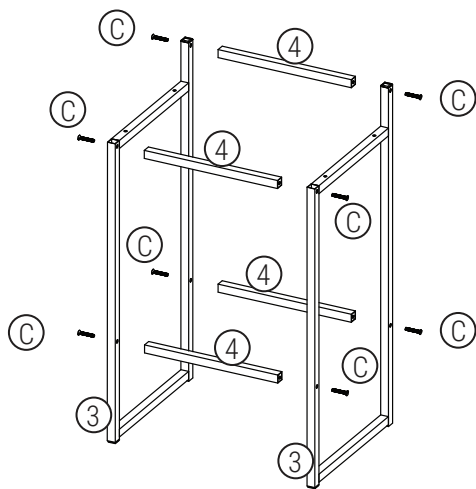

 3°. Fijar los travesaños (4) en los laterales (3) mediante los tornillos (C).

4°. Fixe o assento (1) nas laterais (3) utilizando os parafusos (E).

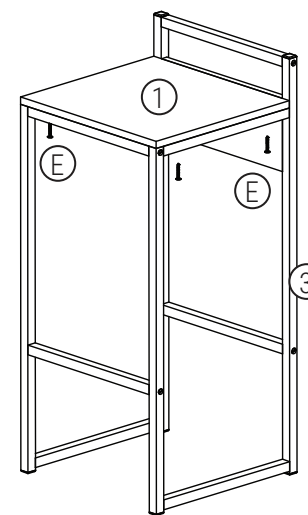

 4°. Fijar el asiento (1) en los laterales (3) mediante los tornillos (E).