

Pronto, montagem concluída!

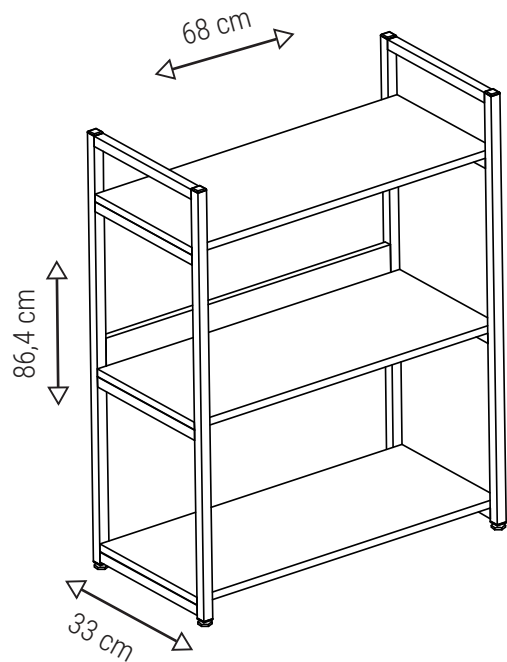

REV00.SET2023

Para limpeza utilize pano limpo e seco. Nunca use produtos abrasivos.

Acesse o termo de garantia em:  
[multivisao.com.br/termos/termodocore.pdf](http://multivisao.com.br/termos/termodocore.pdf)

SAC  
[sac@multivisao.com.br](mailto:sac@multivisao.com.br)  
[multivisao.com.br](http://multivisao.com.br)  
☎ 11 4158-8700 📞 11 97338-5258

GRUPO  
**MULTIVISÃO**<sup>®</sup>  
Desde 1985

# ESTANTE BAIXA

*Estantería baja*

LINHA  
**URBANA**

## INSTRUÇÕES DE MONTAGEM

### Componentes

- 2 Traves laterais ①
- 2 Prateleiras ②
- 1 Travessa ③
- 1 Prateleira com furação ④

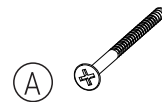
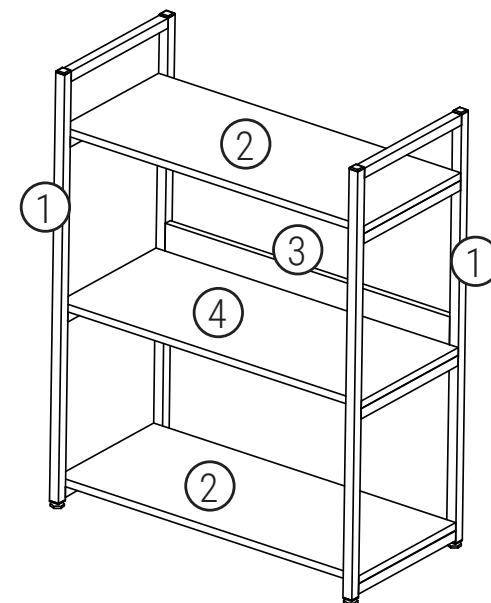

A 4 Parafusos  
4,5 x 40 mm

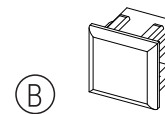

B 4 Ponteiros  
20 x 20

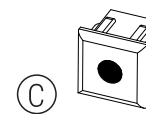

C 4 Ponteiros  
com rosca  
20 x 20

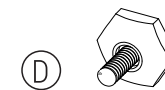

D 4 Niveladores  
1/4



E 12 Parafusos  
5 x 30 mm

### Ferramentas necessárias



Chave Phillips



Martelo

GRUPO  
**MULTIVISÃO**<sup>®</sup>  
Desde 1985

1°. Fixe a travessa ③ na prateleira ④, utilizando os parafusos ①.

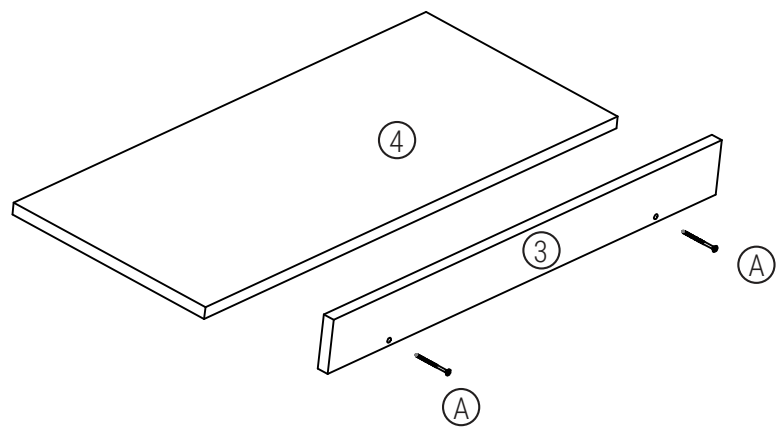

1°. Fije el travesaño ③ al estante ④, utilizando los tornillos ①.

2°. Fixe as ponteiros ② na parte superior das laterais ①.

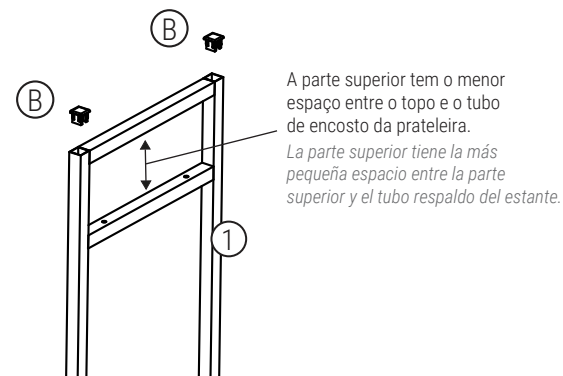

2°. Fije las puntas ② en la parte superior de los lados ①.

3°. Fixe as ponteiros com rosca ③ na parte inferior das laterais ①, em seguida fixe os niveladores ④ nas ponteiros ③.

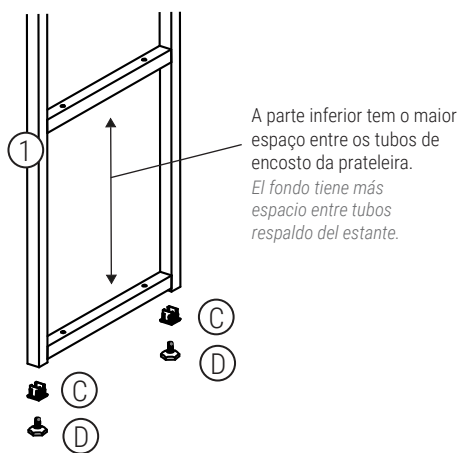

3°. Fije los extremos con hilo ③ en la parte inferior de los lados ①, luego fije niveladores ④ en las puntas ③.

4°. Fixe as prateleiras ② e ④ nas laterais ① utilizando os parafusos ⑤.

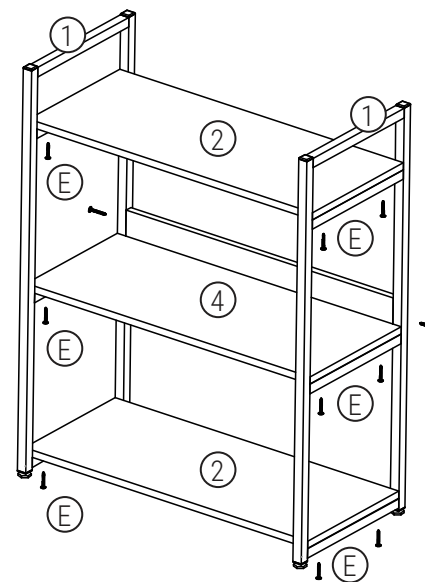

4°. Fijar los estantes ② y ④ en los laterales ① mediante los tornillos ⑤.