

5°. Fixe a base ⑥ nas laterais ② e ⑧ com os parafusos ⑤.

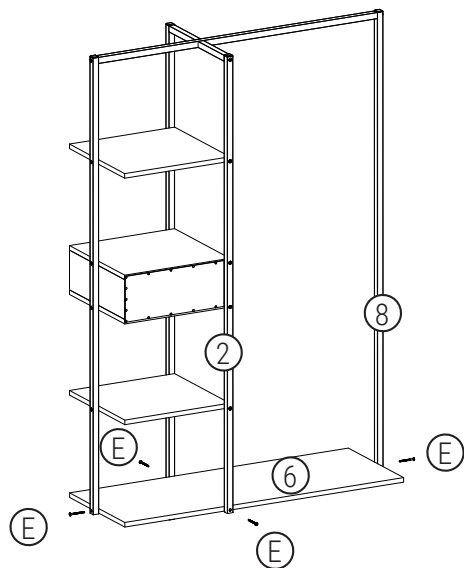

5°. Fije la base ⑥ a los lados ② y ⑧ con los tornillos ⑤.

Pronto, montagem concluída!

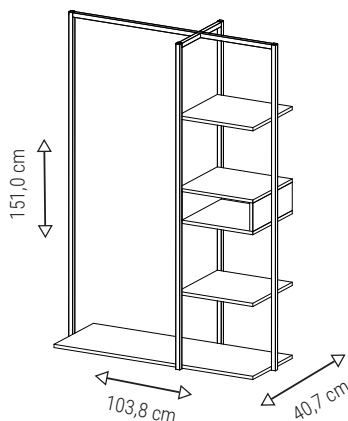

REV00_SET2023

Para limpeza utilize pano limpo e seco. Nunca use produtos abrasivos.

Acesse o termo de garantia em:
multivisao.com.br/termos/termodecore.pdf

SAC
sac@multivisao.com.br
multivisao.com.br
 ☎ 11 4158-8700 📞 11 97338-5258

GRUPO
MULTIVISÃO[®]
 Desde 1985

ARARA ESTANTE

LINHA
URBANA

Armario abierto

INSTRUÇÕES DE MONTAGEM

Componentes

- 1 Topo em + ①
- 4 Laterais de aço com furação ②
- 2 Prateleiras ③
- 1 Prateleiras nicho cavilha ④
- 2 Laterais do nicho ⑤
- 2 Base ⑥
- 1 Fundo do nicho ⑦
- 1 Lateral de aço sem furação ⑧
- 1 Prateleira nicho parafuso ⑨



4 Cavilhas
6 x 30 mm



15 Pregos
10 x 10

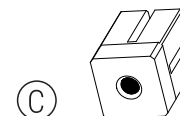

4 Buchas
expansivas



8 Ponteiros
20 x 20

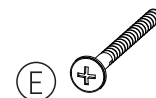

16 Parafusos
5 x 50 mm

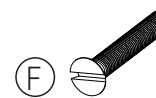

4 Parafusos
1/4 x 1' 1/2

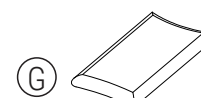

1 Cola

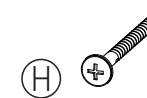

4 Parafusos
4,5 x 50 mm

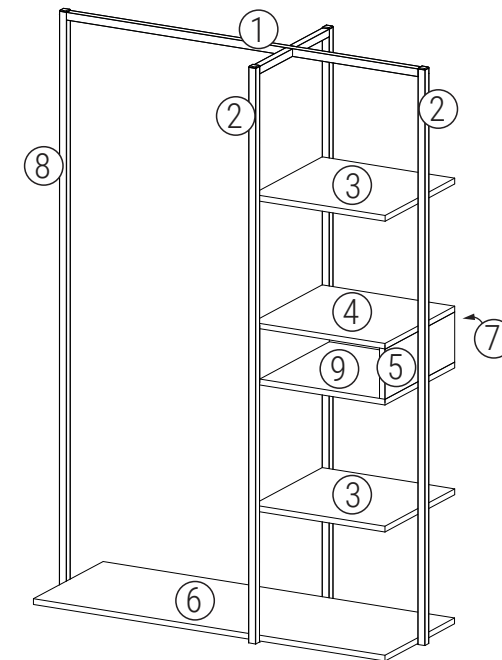

Ferramentas necessárias



Chave Phillips



Martelo

GRUPO
MULTIVISÃO[®]
 Desde 1985

1°. Para a montagem no nicho fixe as prateleiras com furação (4) e (9) nas laterais (5) utilizando a cola (G) e as cavilhas (A) e os parafusos (H). Com os pregos (B) fixe o fundo (7) no nicho já montado.

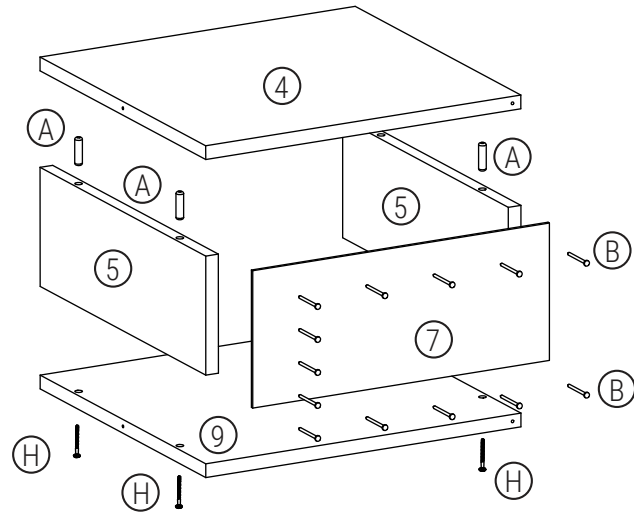

1°. Para montar en el nicho, fije los estantes con los orificios (4) y (9) en los lados (5) usando pegamento (G) y tacos (A) y tornillos (H). Usando los clavos (B), asegure la parte inferior (7) en el nicho ya montado.

2°. Fixe as buchas (C) na peça de aço (1) e as ponteiros (D) nas laterais (2).

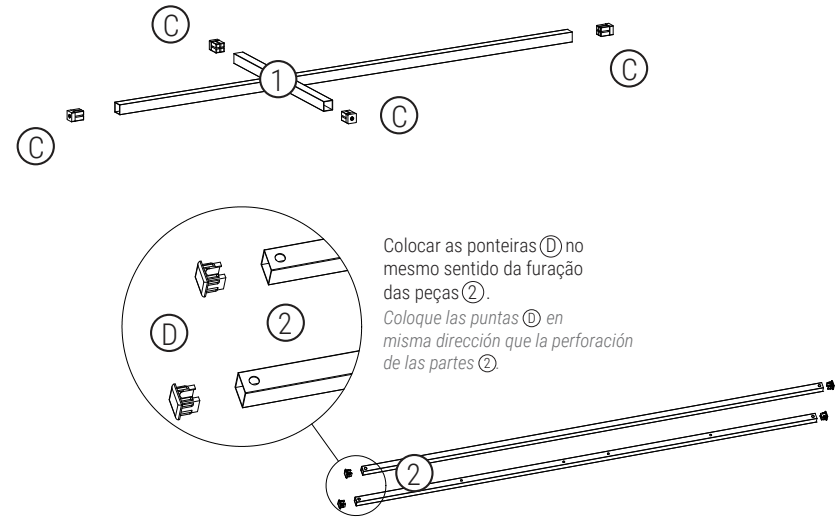

Colocar as ponteiros (D) no mesmo sentido da furação das peças (2).
Coloque las puntas (D) en misma dirección que la perforación de las partes (2).



2°. Fije los casquillos (C) a la pieza de acero (1) y las puntas (D) a los laterales (2).

3°. Fixe as prateleiras (3) e o nicho já montado nas laterais (2).

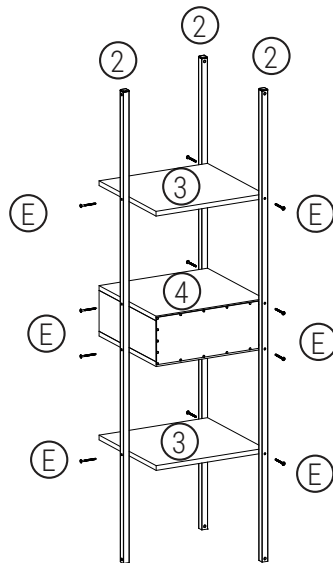

3°. Fije los estantes (3) y el nicho ya montado en los laterales (2).

4°. Fixe as laterais (2) e (8) na peça de aço (1) utilizando os parafusos (F).

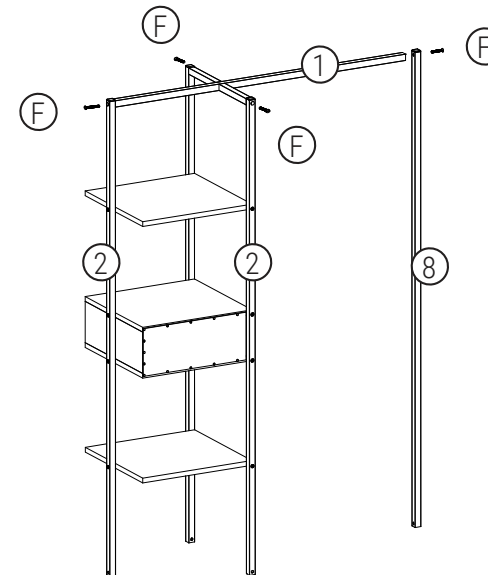

4°. Fije los lados (2) y (8) a la pieza de acero (1) mediante tornillos (F).