

Pronto, montagem concluída!

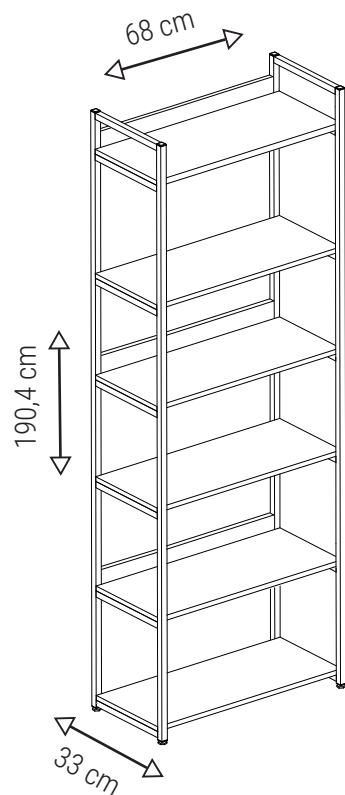

REV00.SET2023

Para limpeza utilize pano limpo e seco. Nunca use produtos abrasivos.

Acesse o termo de garantia em:  
[multivisao.com.br/termos/termodecore.pdf](http://multivisao.com.br/termos/termodecore.pdf)

SAC  
[sac@multivisao.com.br](mailto:sac@multivisao.com.br)  
[multivisao.com.br](http://multivisao.com.br)  
☎ 11 4158-8700 📞 11 97338-5258

GRUPO  
**MULTIVISÃO**<sup>®</sup>  
Desde 1985

# ESTANTE ALTA

*Estantería alta*

LINHA  
**URBANA**

## INSTRUÇÕES DE MONTAGEM

### Componentes

- 2 Traves laterais ①
- 3 Prateleiras ②
- 3 Travessa ③
- 3 Prateleiras com furação ④

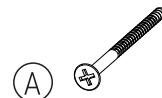
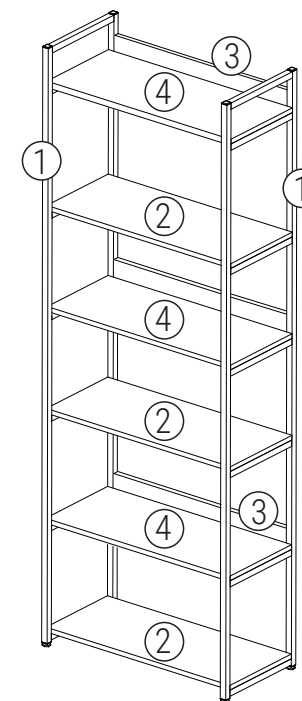

A 12 Parafusos  
4,5 x 40 mm

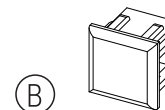

B 4 Ponteiras  
20 x 20

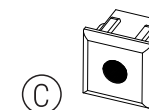

C 4 Ponteiras  
com rosca  
20 x 20



D 4 Niveladores  
1/4



E 24 Parafusos  
5 x 30 mm

### Ferramentas necessárias



Chave Phillips



Martelo

GRUPO  
**MULTIVISÃO**<sup>®</sup>  
Desde 1985

1°. Fixe as travessas (3) nas prateleiras (4), utilizando os parafusos (A).

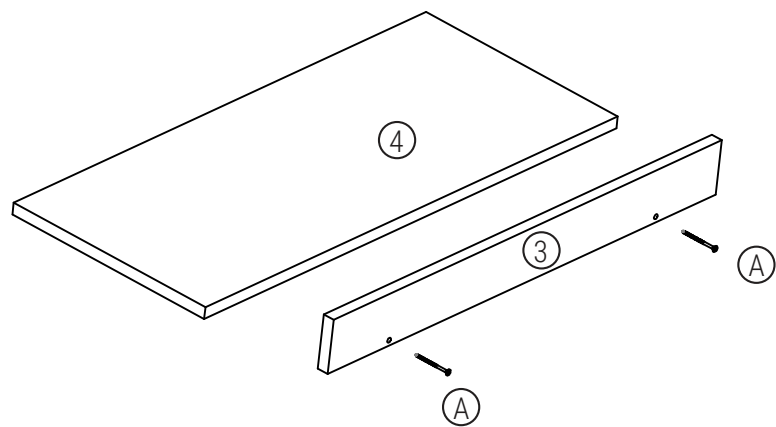

1°. Fijar los travesaños (3) en las repisas (2), utilizando los tornillos (A).

2°. Fixe as ponteiras (B) na parte superior das laterais (1).

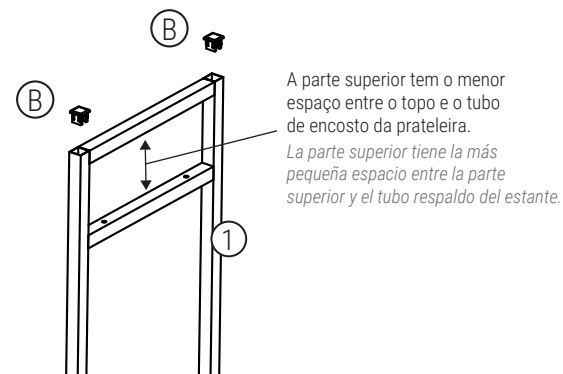

2°. Fije las puntas (B) en la parte superior de los lados (1).

3°. Fixe as ponteiras com rosca (C) na parte inferior das laterais (1), em seguida fixe os niveladores (D) nas ponteiras (C).

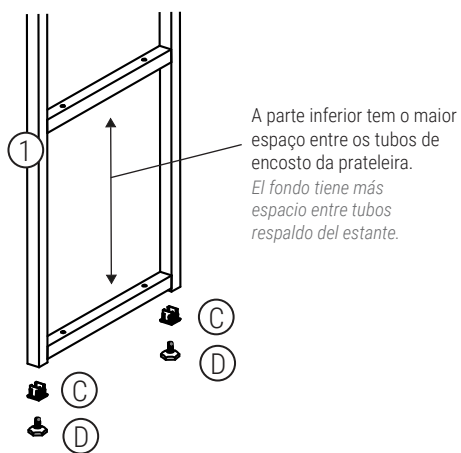

3°. Fije los extremos con hilo (C) en la parte inferior de los lados (1), luego fije niveladores (D) en las puntas (C).

4°. Fixe as prateleiras (2) y (4) nas laterais (1) utilizando os parafusos (E).

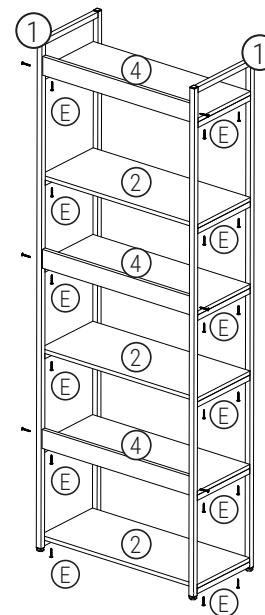

4°. Fijar los estantes (2) y (4) en los laterales (1) mediante los tornillos (E).