

5°. Fixe o projetor nas hastes ④ utilizando os espaçadores ③ as arruelas ② e o parafuso que melhor se adequa ao modelo de seu projetor, e pronto, montagem concluída!

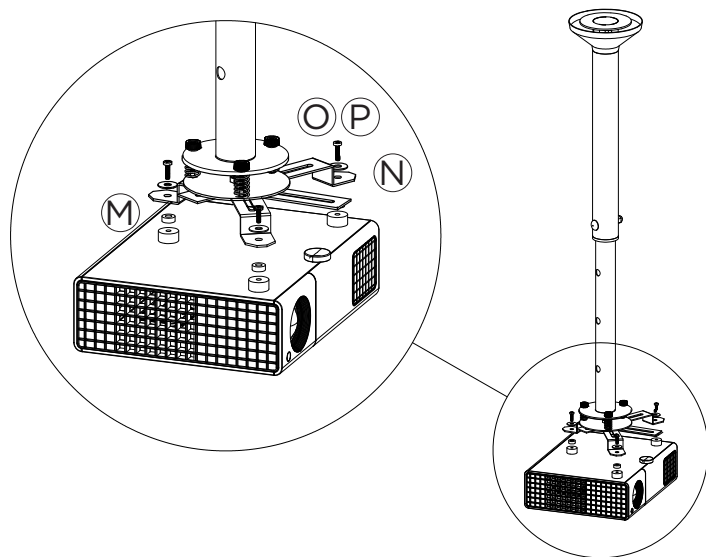

5°. Fijar el proyector en las varillas ④ utilizando los distanciadores ③ y las arandelas ② y el tornillo que mejor se adapta a tu modelo de proyector, y listo, montaje terminado!

Para limpeza utilize pano limpo e seco. Nunca use produtos abrasivos.

Acesse o termo de garantia em:
multivisao.com.br/termos/termosuportes.pdf

SAC
sac@multivisao.com.br 11 4158-8700
multivisao.com.br

GRUPO
MULTIVISÃO[®]
 Desde 1985



MULTIPROJ-M/G PROJETOR

SUPORE DE TETO

Componentes

- 1 Tubo base ①
- 1 Tubo de ajuste ②
- 1 Disco de regulagem ③
- 3 Hastes prolongadoras ④

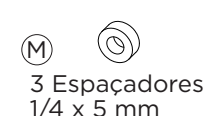
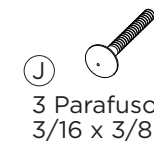
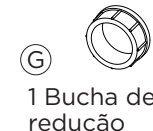
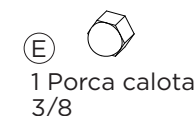
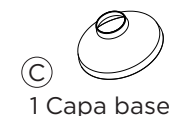
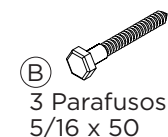

Ferramentas necessárias



Rev1_JUN2022

Instruções de instalação

Instrucciones de instalación

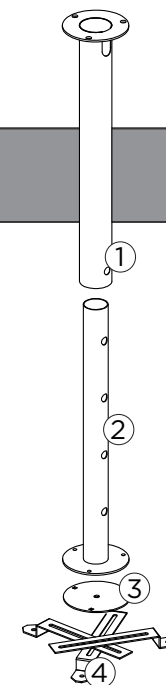

1°. Posicione o suporte ① no local desejado para instalação e faça a marcação dos furos. Faça os furos com a furadeira e a broca indicada, insira as buchas ① nos furos e fixe o suporte com os parafusos ② . Certifique-se de que o suporte esteja firme no teto. Em caso de dúvidas, consulte um especialista.

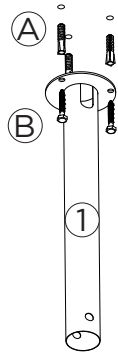
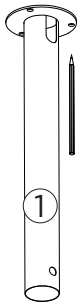

Antes de fazer os furos, assegure-se de que não existam canos ou tubos no local da furação.

Antes de hacer los agujeros, asegúrese de que no hay tuberías o tubos en el sitio de perforación.



1°. Coloque el soporte ① en el lugar deseado para la instalación y marque de agujeros. Perfore los agujeros con el taladro y la broca indicada, inserte los casquillos ① en los agujeros y fije el soporte con los tornillos ② . Asegúrese de que el soporte párese firmemente en lo techo. En caso de duda, consulte a un especialista.

2°. Insira a capa ③ no tubo ① , em seguida encaixe a bucha de redução ④ e a bucha guia ⑤ , para fixar o tubo de ajuste ⑥ no tubo ① com o parafuso ⑦ e porca ⑧ .

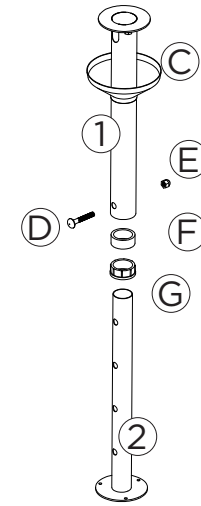

2°. Inserte la tapa ③ en el tubo ① , luego monte el casquillo de reducción ④ y el casquillo guía ⑤ , para fijar el tubo de regulación ⑥ en el tubo ① con el tornillo ⑦ y Tuerca ⑧ .

3°. Fixe as hastes prolongadoras ④ no disco ③ usando o parafuso ⑥ e porca ⑦ .

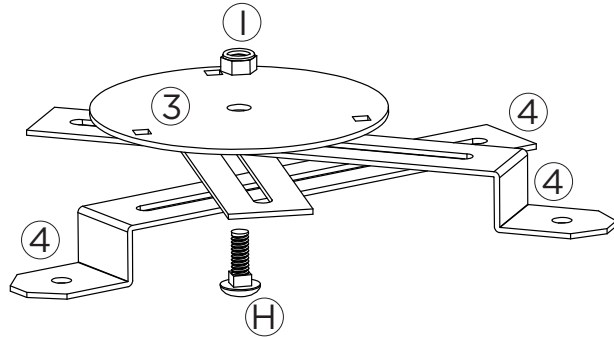

3°. Fije las varillas de extensión ④ en el disco ③ usando el tornillo ⑥ y la tuerca ⑦ .

4°. Fixe o disco ③ já com as hastes ④ no tubo de ajuste ② , para isso, utilize os parafusos ⑧ as molas ⑨ e os micro manipuladores ⑩ . Deixe as Molas ⑨ entre o disco ③ e o tubo de ajuste ② , conforme ilustração abaixo.

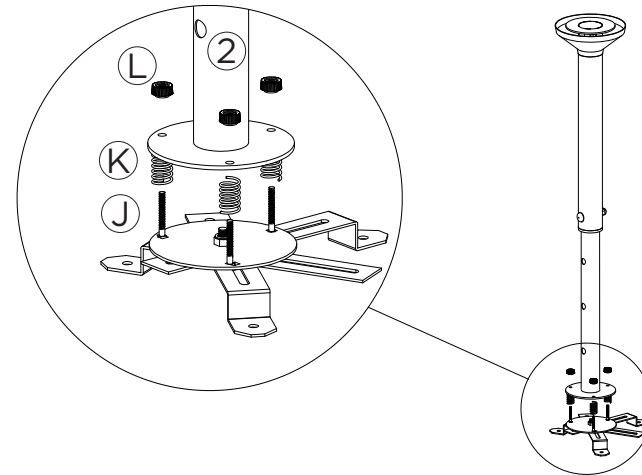

4°. Fijar el disco ③ con las varillas ④ en el tubo de ajuste ② , para ello utilizar el tornillos ⑧ , resortes ⑨ y micro asas ⑩ . Deje los resortes ⑨ entre los disco ③ y tubo de ajuste ② , como se ilustra a continuación.