

5°. Encaixe as laterais superiores ④ no conjunto de guias ⑥ e com a ajuda de um martelo de borracha, bata até as laterais se encontrarem. Em seguida, fixe as laterais superiores ⑤ no arremate ② com os parafusos ⑥.

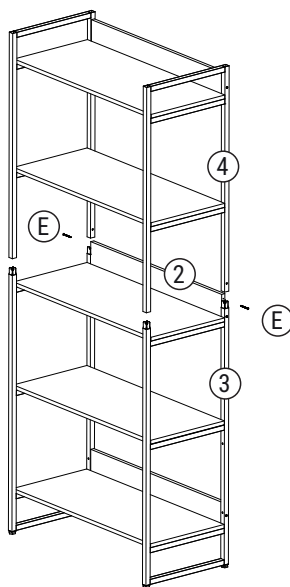

6°. Encaixe as ponteiros ① nas laterais superiores ④, e pronto, montagem concluída.

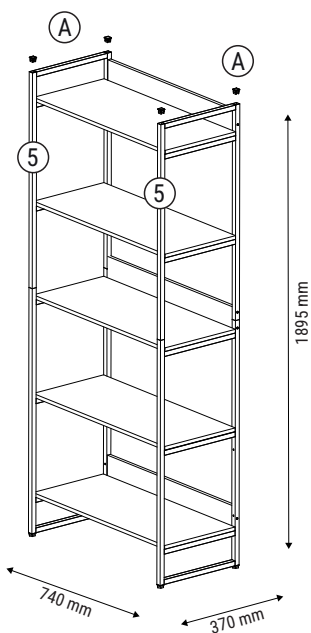

# ESTANTE INDUSTRIAL

## Manual de Montagem

### COMPONENTES:

Dimensões (Comprimento x Largura x Espessura) em mm

- 5 Prateleiras ①  
740 x 328 x 15
- 3 Arremates ②  
700 x 100 x 15
- 2 Laterais inferiores ③  
995 x 370 x 20
- 2 Laterais superiores ④  
880 x 370 x 20

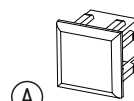
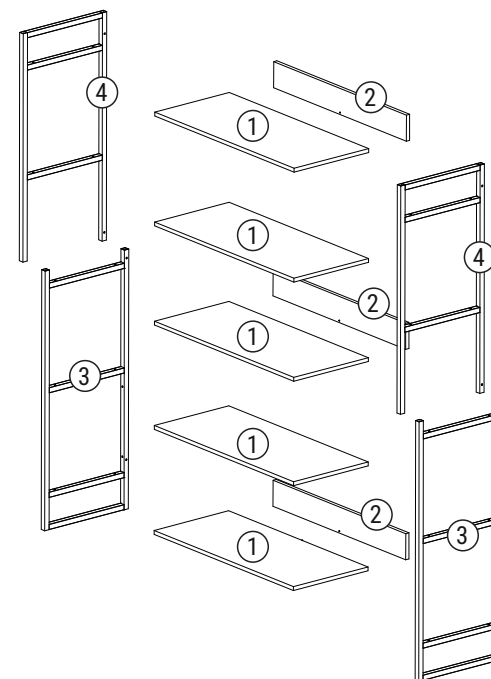

① 4 Ponteiros  
20 x 20



② 4 Ponteiros  
com rosca  
20 x 20



③ 4 Niveladores  
1/4 x 5/8



④ 20 Parafusos  
Flang. 5 x 30

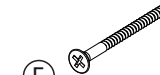

⑤ 11 Parafusos  
4,5 x 40



⑥ 8 Travas  
de encaixe

Ferramentas necessárias



Chave Phillips



Martelo  
de borracha

Para vídeos de montagem acesse:  
[youtube.com/xmontagens](https://www.youtube.com/xmontagens)

Produto indicado para ambiente interno.

Dicas de limpeza: Utilizar pano limpo e seco. Nunca use produtos abrasivos.

1°. Fixe as ponteiros (B) e encaixe os pés niveladores (C) nas laterais inferiores (3).

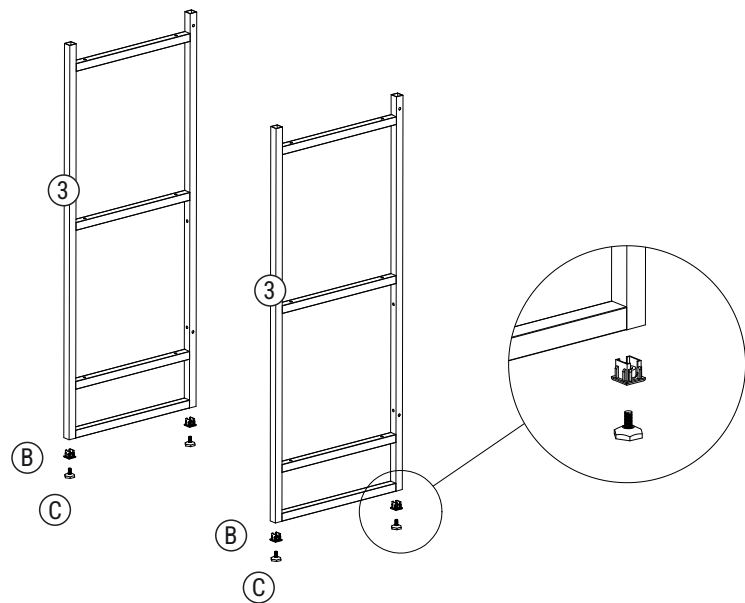

2°. Fixe as prateleiras (1) nas laterais inferiores (3) e superiores (4) utilizando os parafusos (D).

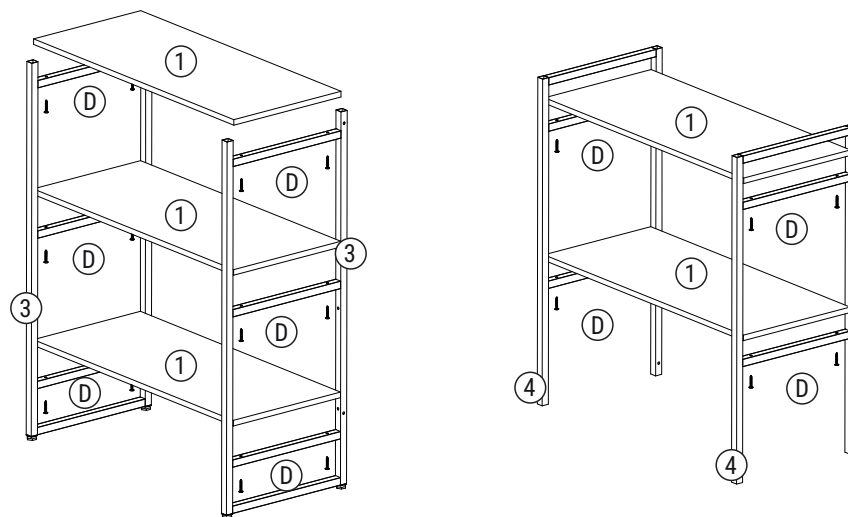

3°. Fixe os arremates (2) nas prateleiras (1) e laterais (4) e (5) com os parafusos (E).

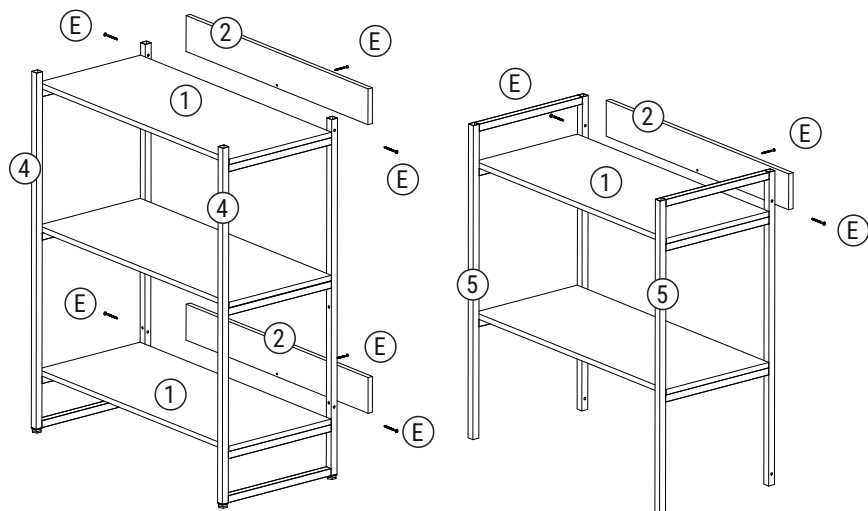

4°. Fixe duas guias (F) entre si e, em seguida com a ajuda de um martelo de boracha, encaixe o conjunto nas extremidades das laterais inferiores (3), conforme imagem abaixo.

